

PF353S-80-1000

## 3PH DELTA COMMERCIAL/INDUSTRIAL FILTER DUAL STAGE / CHASSIS MOUNT

### SPECIFICATIONS

MAX VOLTAGE: 0-520VAC

MAX CURRENT: 80A/LINE

USABLE FREQUENCY: 50/60/400HZ

OPERATING TEMP.: -40 TO 50C

LEAKAGE CURRENT (250V/60HZ): <3.5mA

TYP. WEIGHT, LB(KG): 6.5(2.95)

CLIMATIC CLASS: 25/100/21

DESIGNED AND MANUFACTURED IN ACCORDANCE

WITH THE FOLLOWING STANDARDS:

EN60939-3

CSA22.2 NO. 8

LV DIRECTIVE

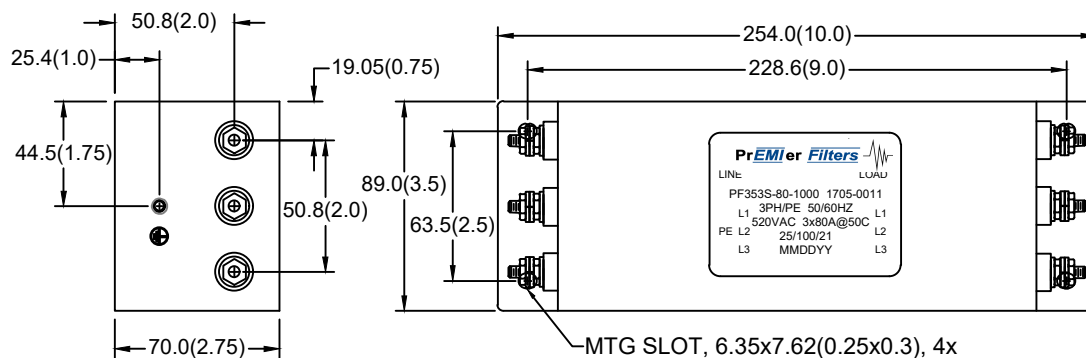

### SCHEMATIC

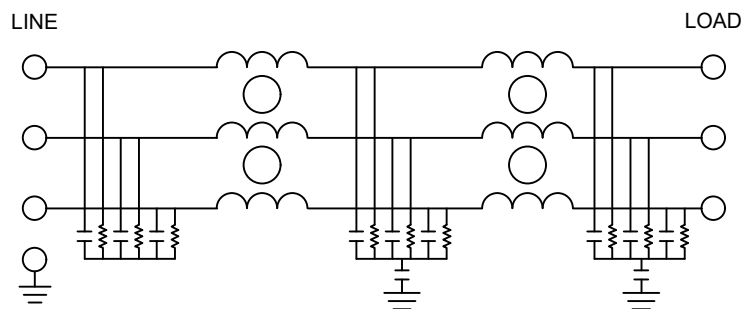

TYPICAL INSERTION LOSS, 50/50 OHM					
FREQ(HZ)	150K	500K	1M	10M	30M
CM, dB	68	75	80	66	45
DM, dB	70	76	78	72	75